

# **NO DIG** *Equipment*

**The Trenchless Technology Specialists**



## **Vacuum Excavator VM1000**

## Three Stage filtration system

Our VM range of Vacuum Excavators are incorporated with a three stage filtration system, including a cyclonic dust separation unit, with a 5 micron washable poly filter element. This three stage filtration system is a very efficient dust separation process, which minimises the frequency of filter cleaning.

## Powerful positive displacement blower

High level continuous flow vacuum pump, without the need to prime or need for the inlet hose to be submerged. Ideal for potholing, service locating, mud removal or general cleaning.

## Acrylic Urethane Paint

We use Acrylic Urethane Paint, which is a premium quality, high performance paint, adding extra years to the life of our Vacuum Excavators and offers the best protection against our harsh Australian climate.

## Hydraulic operated dumping

Remote control operated hydraulic tilt, for quick and easy emptying of the spoil tank.

## High pressure water system

Set at 2500psi, these small yet powerful triplex piston pumps enable you to quickly and safely pothole to determine the exact location of underground utilities and drilling equipment.

## What type of work can you do with a Vacuum Excavator VM1000?

- Cleaning Telstra pits
- Underground service locating
- Clean up construction sites
- Install fence posts
- Live gas pipe maintenance
- Live sewer pipe maintenance
- Installing NBN optical fibre through asbestos pipe
- ..... and much more

## VM1000 Vacuum Excavation Machines include;

- Self contained skid, trailer or truck mounting
- 23.5Hp Kohler Petrol or 26.1Hp Kohler Diesel
- 3" dia Vacuum Suction Hose x 7m long
- 1000 Litre Spoil Tank
- 550cfm Blower, producing ultra efficient vacuum
- 2500psi High Pressure Triplex Water Pump

## VM1000 Vacuum Excavator Trailer, truck or skid mounted



*VM1000 Diesel Trailer Mounted Unit*



*VM1000 Diesel Truck Mounted Unit*

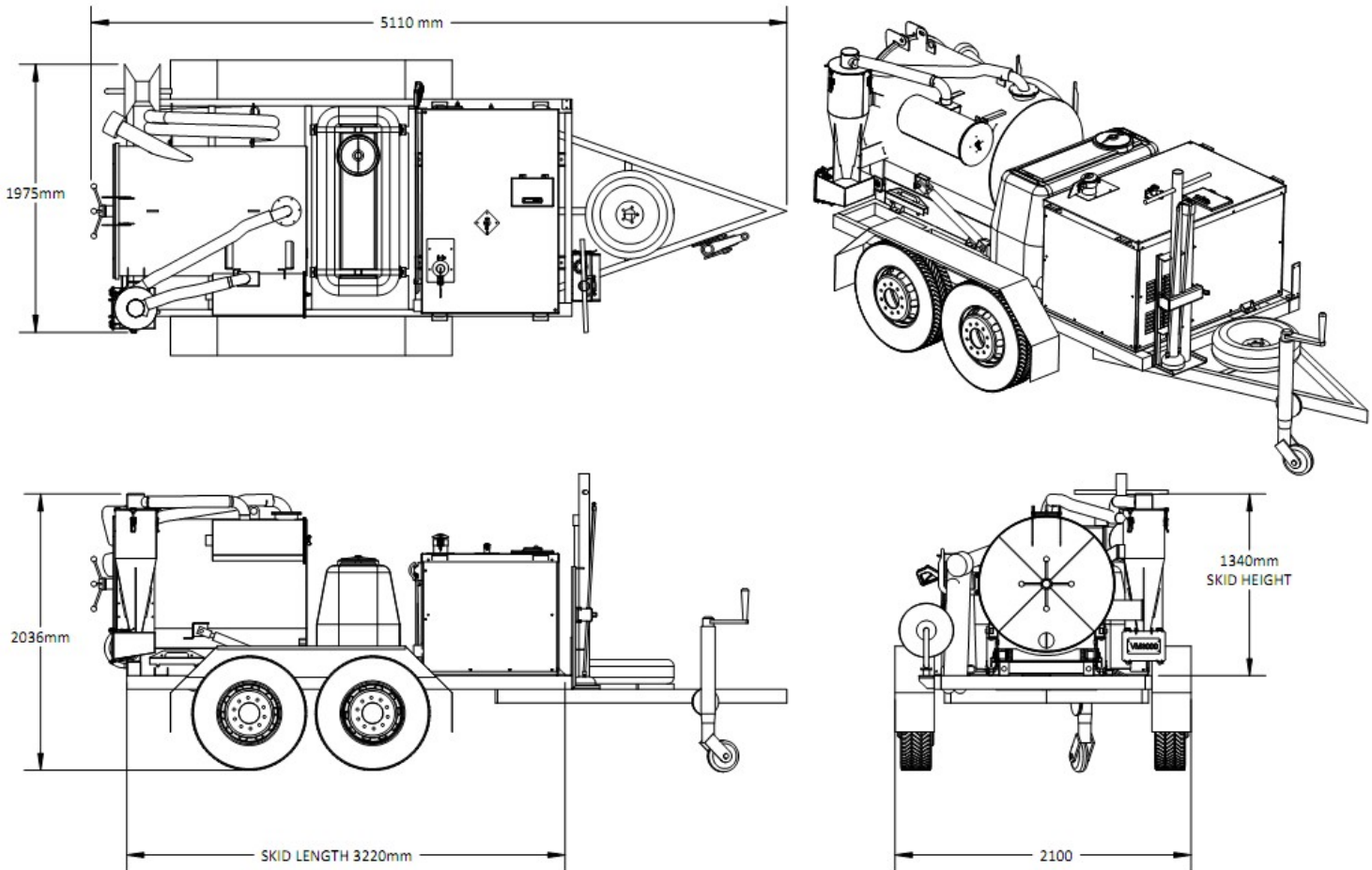

## VM1000 Vacuum Excavator

Vacuum System	550 CFM blower, c/w- 3" dia hose (15"Hg)
Diesel Engine	26.1Hp Kohler KDW1003 Diesel Engine
Spoil Storage Tank	1000 Litre, Hydraulic Tilting
High Pressure Water System	2500psi
Water Tank	500 Litres
Dry Weight	1700 Kg

## Optional Extras

Heavy Duty Trailer	3.5T, c/w- electric brakes (580 Kg)
Skid Frame	c/w- forklifting points
Double Jet Digging Wand	6.5" dia (165 mm) head
Hose Reel	20m or 50m of high pressure hose
HEPA Filter Unit	2 micron, Class H 13 rated
Hose Extension 10 meters	



# **NO DIG** *Equipment*

The Trenchless Technology Specialists



# **NO DIG** *Equipment*

The Trenchless Technology Specialists



**Address:** 15 Wildfire Rd, Maddington WA 6109  
**Postal:** PO Box 2, Maddington WA 6989

**Ph :** 08 9493 0642  
**Fx :** 08 9493 0672

**[www.NoDigEquipment.com.au](http://www.NoDigEquipment.com.au)**  
**[sales@NoDigEquipment.com.au](mailto:sales@NoDigEquipment.com.au)**