

# VERTICAL MAST LIFT

# TM12

DIMENSIONS	TM12
Max. working height	5.7m
Max. platform height (A)	3.7m
Platform size (inside)	0.74m x 1.04m
Overall width (B)	0.76m
Overall length (D)	1.36m
Stowed height (C)	1.7m
Ground clearance	76mm

PERFORMANCE	
Platform capacity (SWL)	227kg
Max. operating wind speed (1 person on platform)	12.5m/s
Max. drive height	3.7m
Max. drive speed (stowed)	3.6km/h
Max. drive speed (elevated)	0.8km/h
Raise/lower time	18/25 sec
Gradeability	25%
Inside turning radius	0.37m
Outside turning radius	1.4m
Tires	305mm. dia. solid rubber, non-marking
Parking brake	2 wheel, spring-applied, hydraulically-released with manual overdrive
Drive system	dual front hydraulic motors
Controls	proportional

POWER	
Power source	24V 4hp DC electric motor 4-220 Ah batteries
Battery charger	90V - 240V - 18 amp automatic

WEIGHT	
Gross weight	776kg

## TURNING RADIUS

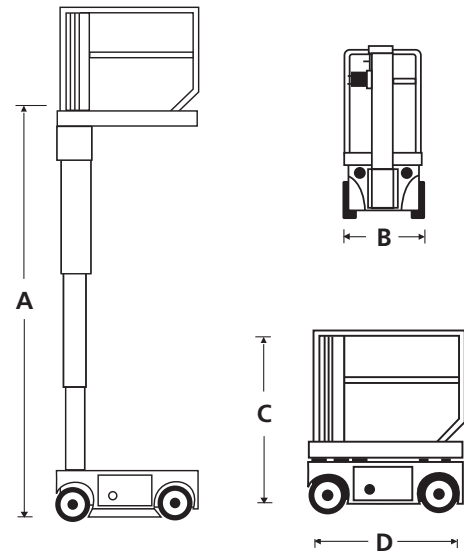
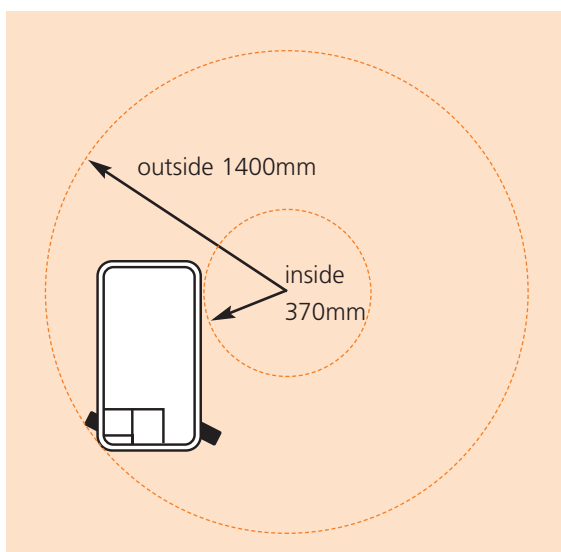

## STANDARD FEATURES

- Proportional controls
- Descent and tilt alarms
- High amp hour rating gives long usage between charges
- Emergency lowering at chassis controls
- Non-marking, solid rubber tyres
- Tie down points
- 2 persons + equipment capacity indoors
- 1 person + equipment capacity outdoors
- Selectable motion alarm
- CE approved

## OPTIONS

- Special paint colours
- Environmental green oil

**snorkel** [www.snorkellifts.com](http://www.snorkellifts.com)

11 Meakin Road,  
Meadowbrook,  
Qld, 4131. Australia.  
t: 07 3489 7000  
e: sales@snorkellifts.com